

UNIVERSITY OF BOLTON

SCHOOL OF ENGINEERING

MSc CIVIL ENGINEERING
MSc CONSTRUCTION PROJECT MANAGEMENT

SEMESTER ONE EXAMINATION 2023/2024

PROJECT MANAGEMENT

MODULE NO: CPM7002

Date: Thursday 11th January 2024

Time: 10:00 – 13:00

INSTRUCTIONS TO CANDIDATES:

This paper contains TWO sections: section 'A' and section 'B'

Section A contains TWO questions: you must answer these TWO questions. They are worth 50 marks.

Section B contains THREE questions: you should answer ANY TWO questions from these three questions. Each of these questions is worth 25 marks.

Marks for parts of questions are shown in brackets.

This examination paper carries a total of 100 marks.

All working must be shown. A numerical solution to a question obtained by programming an electronic calculator will not be accepted.

School of Engineering
 MSc Civil Engineering & Construction Project Management
 Semester 1 Examination 2023/2024
 Project Management
 Module No: CPM7002

Section A – Compulsory Questions

Question One

Table Q1 contains 14 construction activities and their duration in a project. The construction manager thought the following dependency best describes the construction process.

Activity	Duration Days	Activity	Duration Days
A	2	H	10
B	2	I	8
C	6	J	8
D	3	K	4
E	3	L	3
F	5	M	2
G	5	N	2

Table Q1

Construction dependency:

- B and C can start the project
- D and E succeed B
- F and G succeed C
- J follows B
- H succeeds D
- I follows E and merges with J into M
- N succeeds M
- F follows C and precedes L
- K follows G and merges with F into L
- N and L merge into A
- A completes the project

Complete the following tasks:

- (a) Draw a network diagram for the above activities using Precedence Diagram. **(8 marks)**
- (b) Carry out forward and backward passes to determine earliest & latest times and earliest & latest finish times for each activity and the network critical path. **(8 marks)**
- (c) Calculate the Total Float (TF) and Total Time Available (TTA) for all non-critical activities. **(8 marks)**
- (d) If the construction manager discovered that duration of activity, G should be 10 days instead of 5 days and that of activity K should be 9 days instead of 4 days. Explain how this would affect the network critical path and the total duration of the project. **(6 marks)**

Total 30 marks

Please turn the page...

School of Engineering
MSc Civil Engineering & Construction Project Management
Semester 1 Examination 2023/2024
Project Management
Module No: CPM7002

Question Two

- (a) Within the context of PRINCE2, explain what are meant by Principles, Themes and Processes in managing a project and show how they fit in the PRINCE2 structure.
(5 marks)
- (b) PRINCE2 manages projects by controlling performance of six variables involved in any project. Discuss these variables and justify their choice.
(5 marks)
- (c) Appraise the roles and responsibilities of a project manager, and critically discuss the skills and attributes required to be an effective project manager.
(5 marks)
- (d) Critically discuss the five key stages through which groups or teams pass (Tuckman's Model) and relate that to the nature of the construction industry.
(5 marks)

Total 20 marks

Please turn the page...

Section B – Answer any two questions

Question Three

- (a) Discuss the main objective of resources aggregation in a construction project and mention some of the techniques used to achieve it. **(5 marks)**
- (b) The network diagram in **Figure Q3** represents a planning programme for construction activities in a project as viewed by the construction manager. Activities duration are given in weeks.
- (i) Analyse the network and determine the earliest start and latest finish times for each activity together with the network critical path. **(10 marks)**
- (ii) If all project activities in **Figure Q3** require continuous craneage. The contractor owns one crane costing £1575/week and the cheapest crane hire would cost £1980/week. Produce a full annotated bar chart for the activities on the graph paper provided (use landscape orientation) and determine the **minimum cost** of craneage to the contractor. **(10 marks)**

Total 25 marks

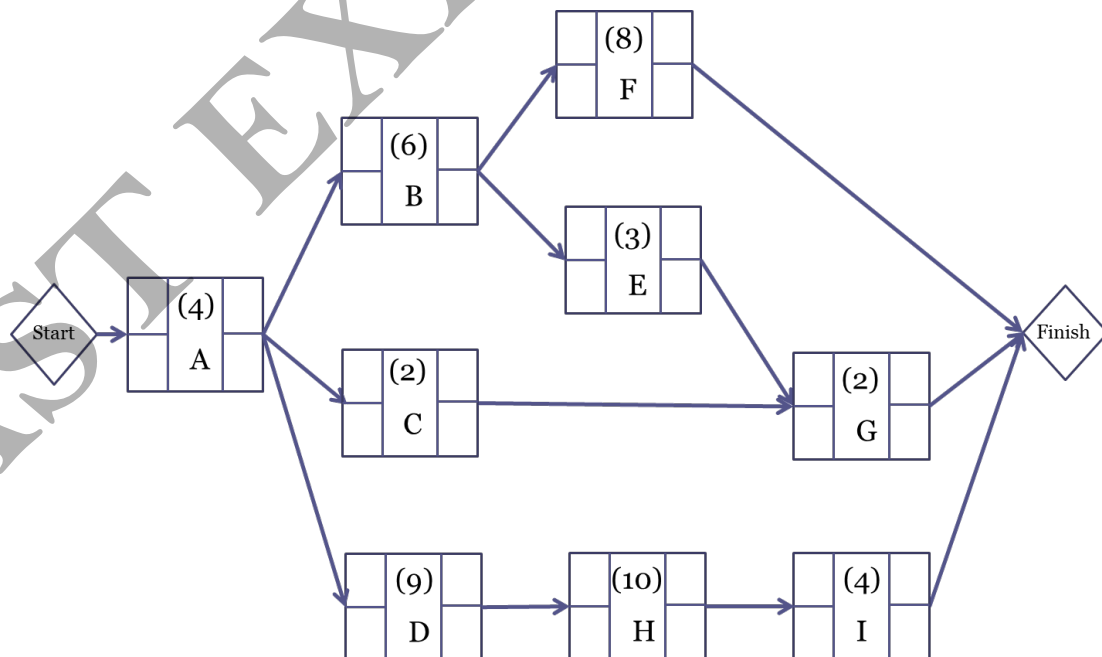

Figure Q3

Please turn the page...

School of Engineering
MSc Civil Engineering & Construction Project Management
Semester 1 Examination 2023/2024
Project Management
Module No: CPM7002

Question Four

- (a) Critically discuss the six main steps of value engineering, and the main tasks and outcomes of each stage.

(12 marks)

- (b) Critically evaluate the process of Project Risk Management and how each stage of risk analysis and risk response could be conducted including the techniques/tools used in each stage.

(13 marks)

Total 25 marks

Question Five

- (a) Appraise the value of various parts of the Building Cost information Service in accurately predicting the cost of construction projects.

(15 marks)

- (b) Discuss difficulties experienced by the construction sector when forecasting costs of major projects in current market conditions.

(10 marks)

Total 25 marks

END OF QUESTIONS